

## OPERATING PERFORMANCE

Operating Weight	1,680 kg
Bucket Capacity (Heaped)	0.038 m <sup>3</sup>
Slew Speed	9.2 min <sup>-1</sup>
Travel Speed	
1st	2.2 km/h
2nd	4.2 km/h
Gradeability	15°
Ground Pressure	27.0 kPa
Maximum Bucket Breakout Force	14.0 kN
Maximum Arm Digging Force (930 mm Arm)	9.5 kN
Maximum Arm Digging Force (1,130 mm Arm)	8.2 kN
Traction Force	19.4 kN
Boom Swing Angle (Left/Right)	70° / 50°

## ENGINE

Model	Yanmar / 3TNV70
Rated Output (ISO 14396)	11.5 kW/2,400 min <sup>-1</sup>
Maximum Torque	52.6 Nm/1,800 min <sup>-1</sup>
Displacement	854 ml
Alternator	12 V - 0.48 kW
Battery (IEC 60095-1)	12 V - 48 A h

## FLUID CAPACITY

Engine Lubrication	2.8 L
Cooling System	3.9 L
Fuel Tank Capacity	22.0 L
Hydraulic Reservoir Capacity	16.1 L
Hydraulic System Capacity	24.0 L

## HYDRAULIC SYSTEM

P1, P2	Variable Displacement Pump
Flow Rate	16.8 L/min
Relief Pressure	21.0 MPa
P3	Gear Pump
Flow Rate	10.8 L/min
Relief Pressure	20.0 MPa
Service Port 1	
Flow Rate	33.6 L/min
Hydraulic Pressure	21.0 MPa
Service Port 2	
Flow Rate	10.8 L/min
Hydraulic Pressure	20.0 MPa
Service Port 3	
Hydraulic Pressure	20.0 MPa

## SAFETY and HEALTH

Vibration Levels	
Hand / Arm	≤ 2.5 m/s <sup>2</sup>
Body	≤ 0.5 m/s <sup>2</sup>
Noise Level	
Sound Power Level	LWA 93 dB



# TB217R Compact Excavator

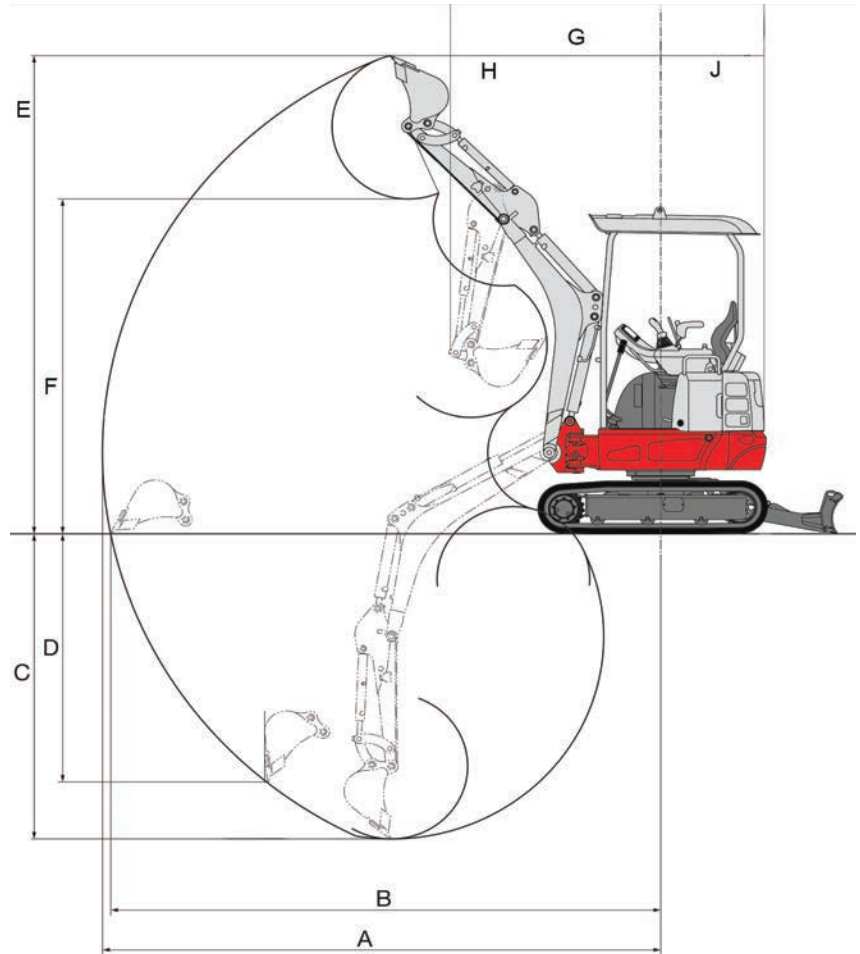
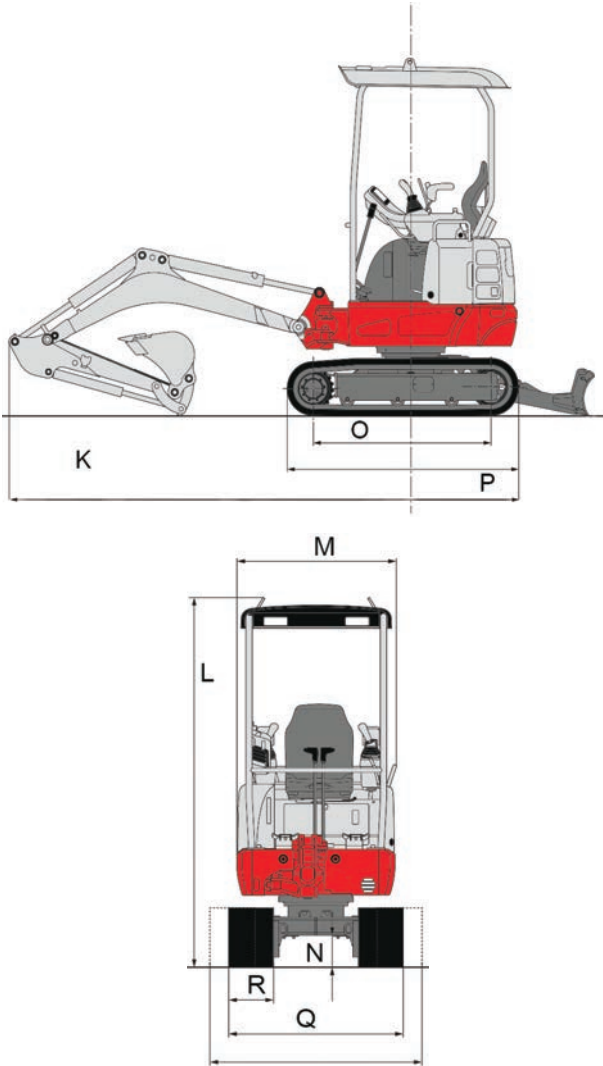

MACHINE DIMENSIONS		930 mm Arm	1,130 mm Arm
A	Maximum Reach	3,815 mm	4,000 mm
B	Maximum Reach at Ground Level	3,760 mm	3,945 mm
C	Maximum Digging Depth	2,190 mm	2,390 mm
D	Maximum Vertical Digging Depth	1,780 mm	1,970 mm
E	Maximum Height of Cutting Edge	3,430 mm	3,570 mm
F	Maximum Dumping Height	2,400 mm	2,545 mm
G	Front Swing Radius	1,450 mm	1,470 mm
H	Front Swing Radius with Boom Offset	1,185 mm	1,210 mm
J	Slew Radius	730 mm	730 mm
K	Overall Length	3,460 mm	3,460 mm
L	Overall Height	2,345 mm	2,345 mm
M	Upper Structure Overall Width	980 mm	980 mm
N	Ground Clearance	205 mm	205 mm
O	Crawler Base	1,205 mm	1,205 mm
P	Crawler Overall Length	1,570 mm	1,570 mm
Q	Crawler Overall Width - Crawler Retracted	980 mm	980 mm
Q'	Crawler Overall Width - Crawler Extended	1,300 mm	1,300 mm
R	Crawler Shoe Width	230 mm	230 mm